

# D640

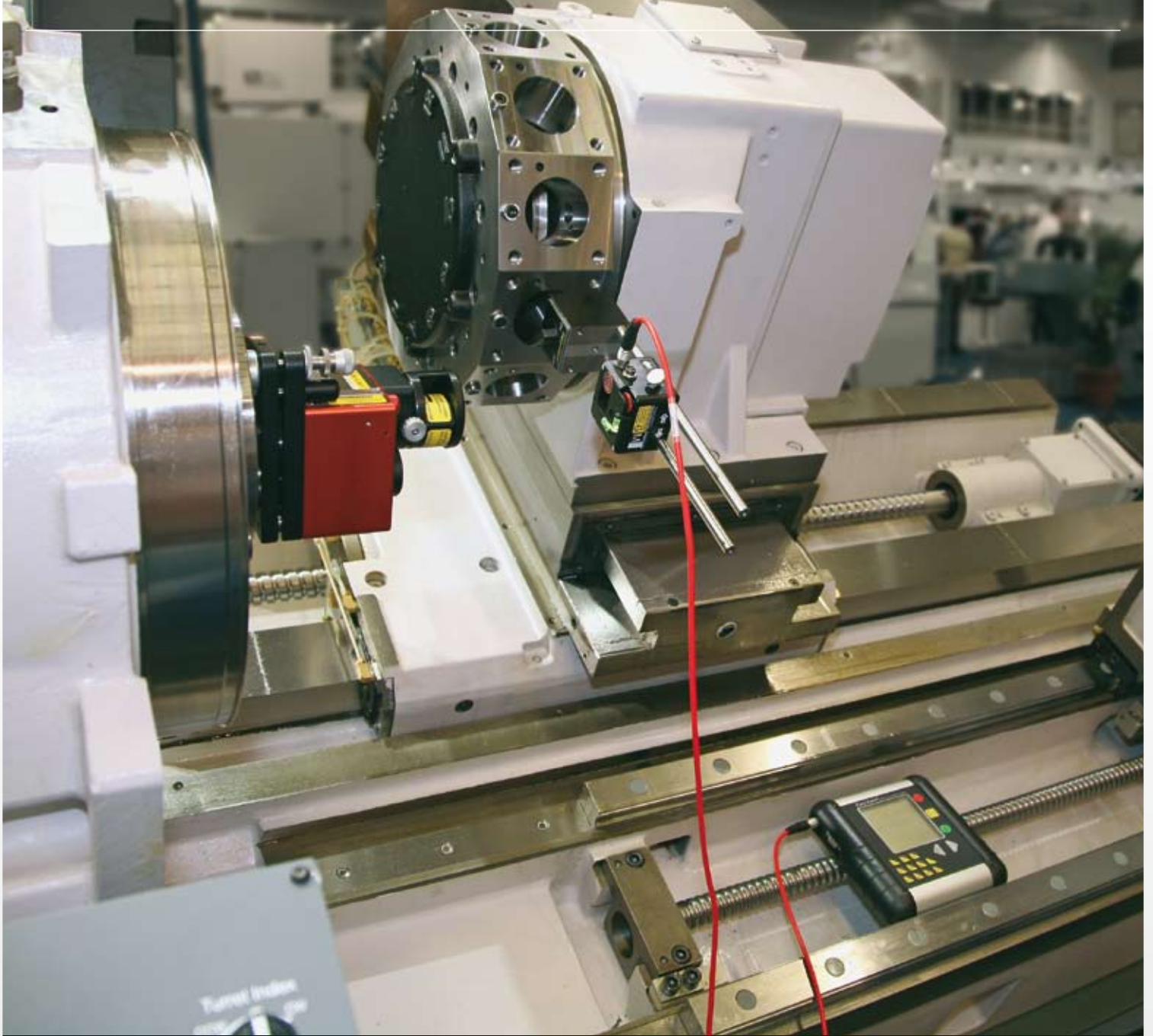

## MACHINE TOOL APPLICATIONS

*Straightness, Flatness, Squareness, Spindle direction etc.*

**EASY-LASER®**



## THE EASY WAY TO MEASURE AND ALIGN YOUR MACHINE TOOLS

In order to meet quality requirements and minimise the number of waste work pieces, the checking and alignment of machine tools is essential. The most important thing to check is the geometry of the machine; not even a precisely calibrated linear motion can compensate for a crooked movement or uneven surface. The correct machine geometry is the basis for being able to produce parts that remain within the tolerances.

The Easy-Laser® D640 Machine tool system can handle most tasks in this field, despite the fact that there is considerable variation as regards to machine design: boring machines, vertical, horizontal and portal milling machines, lathes, vertical lathes, drilling machines, automatic drills, water cutting machines, presses, etc.

Compared to conventional methods, such as dial gauges, etc work can be carried out much more quickly with the use of a laser measurement system. There are many reasons why:

### Laser measurement system

- Light and handy equipment = shorter time for preparations and measurements
- Possible to measure and align at long distances = greater accuracy
- Possible to measure both X and Y (Z) directions at the same time = saves time
- The reference (laser beam) is always 100% straight
- It is possible to create documentation of the measurement results via printer and to PC

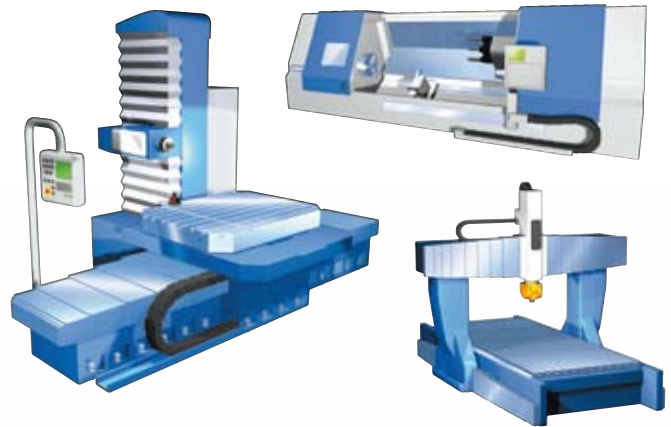

### What you can check with the Easy-Laser® D640 Machine tool system:

- Straightness of machine axis
- Spindle direction
- Spindle to spindle/tail stock
- Squareness between machine axis
- Flatness on machine table or machine bed
- Bearing play check
- Bearing condition (g)

## STRAIGHTNESS

Measuring straightness, like all other geometry measurements, relies on the use of the laser beam as a reference. A great advantage is that you can measure the horizontal and vertical direction at the same time. You position the detector at selected measurement points and record the values. After measuring, set two suitable measurement points to zero, then convert the remaining points to this new reference line. New measurement points can be added to or removed from the existing set.

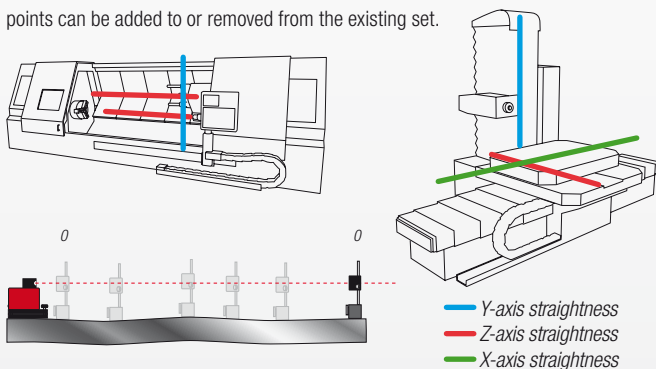

## SQUARENESS

When measuring squareness, first record two measurement values on a single object to create a reference for the angle. Then use the built-in penta prism in laser transmitter D22, which deflects the laser beam 90°, and record two new measurement values on the second object. The measurement values are converted into an angular value, showing any deviation from 90° in the second object.

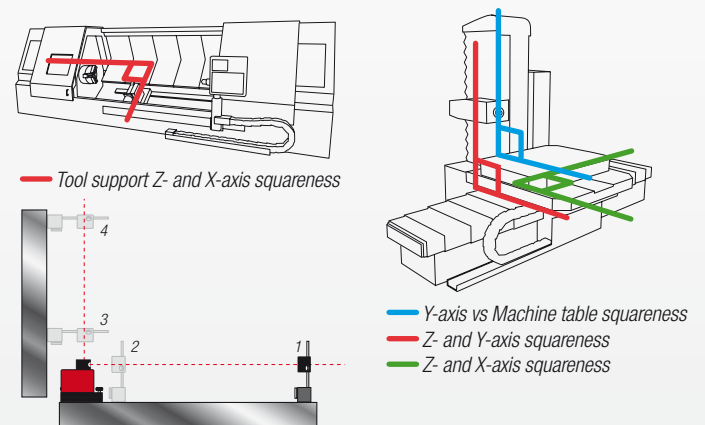

## SPINDLE DIRECTION

When measuring spindle direction, place the laser transmitter D146 in the machine spindle and the detector on the section that can be moved along with the machine's working area. Record the first measurement value at the first measurement point, then rotate the spindle 180° and record the next value. Then move the detector to the second measurement point and repeat the procedure. To eliminate any static sag, laser transmitter D146 can be used with a rotating spindle while measuring.

Another application is alignment of secondary spindle with main spindle. Here it is beneficial to use both measuring units (combined laser/detector).

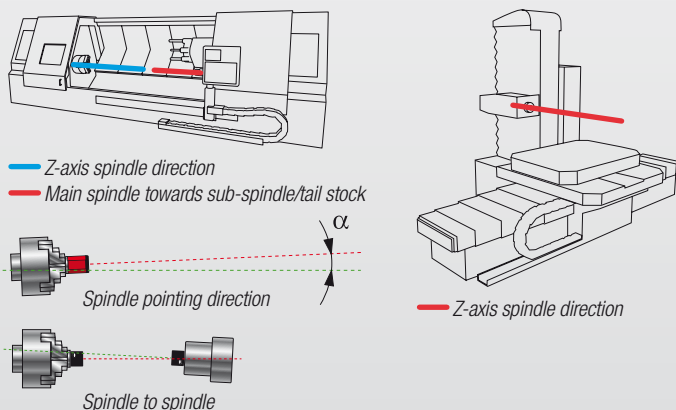

## FLATNESS

Flatness can be measured on a rectangular or circular plane. The only difference is which measurement program is most suitable. Position the detector at selected measurement points and record the values. After measuring, set three of the measurement points to zero, then the remaining points are recalculated to the new reference plane formed.

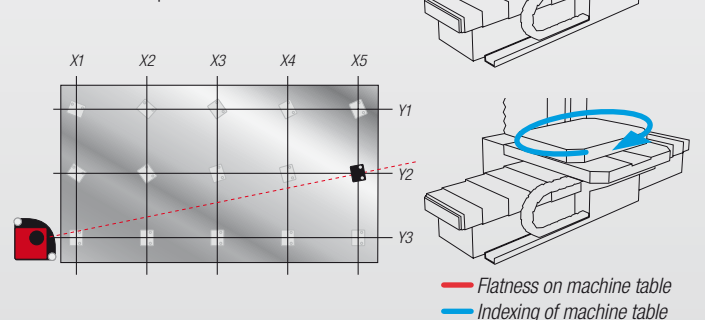

## THE SOFTWARE DOES THE JOB

The key to quick and easy measurements is a measurement program that helps you achieve your best. We have therefore included a large number of measurement programs in the display unit as standard. All measurement programs guide the user step-by-step through the entire measurement procedure. Complicated calculations of angles and measurement values are handled by the program. In other words, you leave most of the thinking and all difficult calculations to the measurement system.

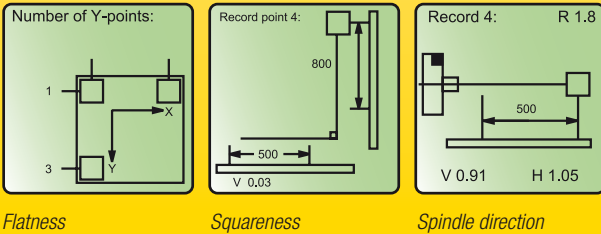

## DOCUMENTATION OF MEASUREMENT RESULT

When measurement is complete, you have several options for documenting the results. Choose the one that is best suited for the situation, depending, for example, on whether further analysis is needed or whether a measurement report needs to be produced. The Display unit has an RS232/USB interface for connection to a printer or PC communication.



### SAVE IN THE DISPLAY UNIT

The storage memory is very large. Up to 7000 points for geometry measurement can be saved.



### PRINT

Quickly print all measurement data locally with the battery operated thermal printer (optional). This is useful, for example, if you don't want to connect to a PC.



### TRANSFER DATA TO PC

With the EasyLink™ program for Windows® (included), you can produce professional reports with both measurement data and pictures, export to spreadsheets such as Excel®, etc.

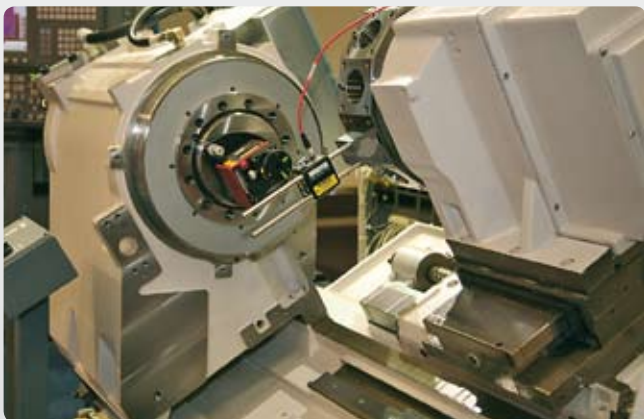

Objects up to 40 m [132 feet] can be measured. The detector reads 2-axis measurement values, with a resolution of 0.001 mm [0.05 mils].

## LASER TRANSMITTER D22 SWIVELLING

For measuring Flatness, Straightness, Squareness, Parallelism and Spindle Direction. The laser beam can sweep 360° with a measurement distance of 40 metres [130'] in radius. The beam can be deflected at 90° to the sweep, within 0.01mm/m [0.5 mils/thou].

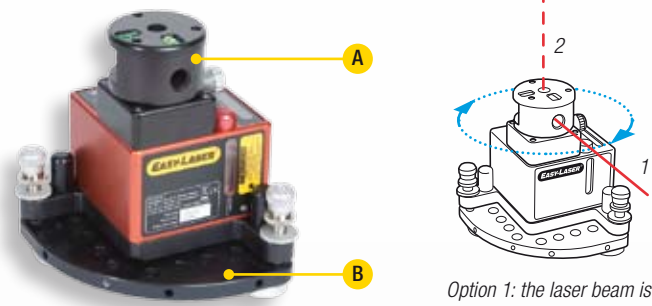

A. Rotatable head with angular prism  
B. Tilting table

Option 1: the laser beam is used for a 360° sweep.  
Option 2: the laser beam is angled at 90° to the sweep.

## LASER TRANSMITTER D146 SPINDLE

For measuring Spindle Direction and Straightness. Can be used in a rotating spindle (max. 2000rpm). A clamping pin can also be fitted by the laser opening, for use when aligning bar feeders, for example. Measurement distance 20 metres [65'].

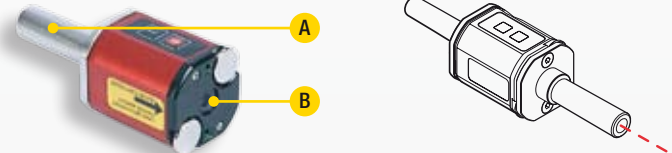

A. Clamping pin  
B. Laser aperture

Option: The extra clamping pin can be fitted by the laser opening.

## MEASURING UNITS

Laser diode and PSD detector in one compact housing. Perfect for alignment of two to each other pointing shafts, for example main spindle to sub-spindle. One of the units (M) has a 2-axis detector which makes it possible to read the position in two directions at the same time. This unit is therefore also used when measuring with one of the separate laser transmitters D22 or D146, but then without turning the laser on.

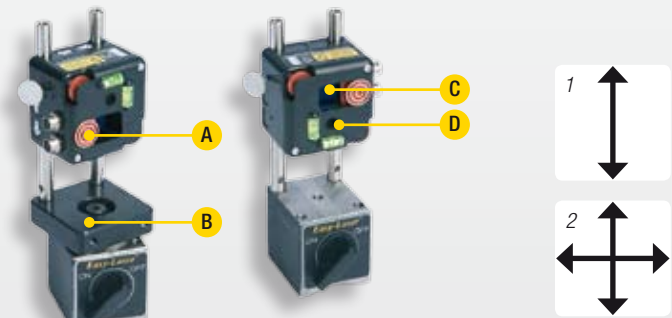

A. Slidable rough alignment target  
B. Magnet base with rotatable head  
C. PSD (detector surface)  
D. Laser aperture

1. The S unit has a 1 axis PSD  
2. The M unit has a 2 axis PSD

## VIBROMETER

With the Vibrometer you check the bearing condition (g-value) of the spindle bearing. The result can be documented.

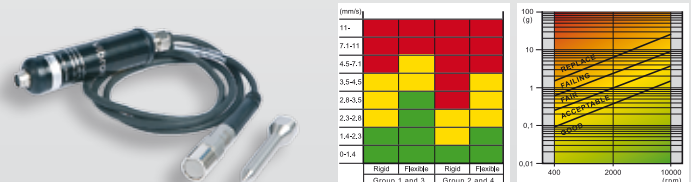

## TECHNICAL SPECIFICATIONS

## System

Weight of system	18.3 kg [40.3 lbs]
Transportation case	WxHxD: 700x370x210 mm [27.5"x14.6"x8.3"]
Temperature range	0–50°C [32–122°F]
Relative humidity	10–95%

## Display unit

Type of display	Backlit dot matrix LCD
Display size	73x73 mm [2.87"x2.87"]
Displayed resolution	Changeable: 0.1, 0.01, 0.001mm; 5, 0.5, 0.05 mils/thou
Battery	4 x 1.5 V R14 (C)
Operating time	48 hours appr.
Output port	RS232 for printer and PC communication
Keyboard	Membrane alphanumeric multi function
Memory	Storage for 7000 measurement positions
Settings	Value filtering, contrast and unit (mil/thou/mm)
Housing material	Anodized aluminium / ABS-plastics
Dimensions	WxHxD: 180x180x45 mm [7.1"x7.1"x1.8"]
Weight	1250 g [2.8 lbs]

## Laser transmitter D22

Type of laser	Diode laser
Laser wavelength	635–670 nm, visible red light
Laser Safety Class	Class 2
Output	< 1 mW
Beam diameter	6 mm [1/4"] at aperture
Working area, range	40-metre radius [130']
Type of battery	1 x R14 (C)
Operating time/battery	approx. 24 hours
Levelling range	± 30 mm/m [± 1.7°]
3 x spirit vials' scaling	0.02 mm/m
Squareness between laser beams	0.01 mm/m [2 arc sec.]
Flatness of sweep	0.02 mm
Fine turning	0.1 mm/m [20 arc sec.]
2 x spirit vials for rotation	5 mm/m
Housing material	Aluminium
Dimensions	WxHxD: 139x169x139 mm [5.47"x6.64"x5.47"]
Weight	2650 g [5.8 lbs]

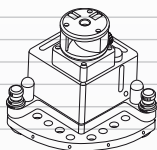

## Laser transmitter D146

Type of laser	Diode laser
Laser wavelength	635–670 nm, visible red light
Laser Safety Class	Class 2
Output	< 1 mW
Beam diameter	3 mm [1/8"] at aperture
Measurement distance	20 m [65']
Type of battery	1 x R6 (AA)
Operating time/battery	approx. 6 hours
Max speed	2,000 rpm
Clamping pin	∅ 20 mm, L= 60 mm [∅ 0.78", L=2.36"]
Housing material	Anodized aluminium
Dimensions (without pin)	∅ 60 mm, L=98 mm [∅ 2.36", L=3.86"]
Weight (with pin)	470 g [16.5 oz]



## Measuring units (S, M)

Type of laser	Diode laser
Laser wavelength	635–670 nm, visible red light
Laser Safety Class	Class 2
Laser output power	< 1 mW
Resolution	0.001 mm [0.05 mils]
Type of detector, S unit	1 axis PSD 18x18 mm [0.71" sq]
Type of detector, M unit	2 axis PSD 18x18 mm [0.71" sq]
Spirit vials	Resolution 0.5°
Inclinometers	Electronic inclinometers, 0.1° resolution
Thermal sensors	±1°C accuracy
Protection	No influence from ambient light
Housing material	Anodized aluminium
Dimensions	WxHxD: 60x60x50 mm [2.36"x2.36"x1.97"]
Weight	198 g [7 oz]

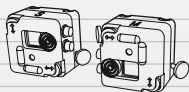

## Vibrometer

Probe sensitivity	100 mV/g ±10%
Dimensions	Magnet: L=20 mm [4/5"], ∅=15 mm [19/32"] Gauge tip: L=65 mm [2 1/2"]

## Magnet bases

Holding power	800 N
---------------	-------

## Rods

Material	Stainless steel
Length	60 mm, 120 mm [2.36", 4.72"]

## Cables

Type	With push/pull connectors
Length	2 m, 5m [78.74", 196.85"]

## Offset bracket

Displacement	32 mm [1.26"]
--------------	---------------

## Accessories (examples)

Tripod	Part No. 12-0269
Printer	Part No. 03-0032. Thermal printer with charger.
Shaft bracket	Part No. 12-0016. V-bracket with chain.

## SYSTEM D640 MACHINE TOOL

Part No. 12-0552

- 1 Display unit D279 (27 programs)
  - 2 Measuring units (S: 1 axis, M: 2 axis)
  - 1 D22 Laser transmitter Swivelling
  - 1 D146 Laser transmitter Spindle with clamping pin ∅ 20 mm
  - 1 Clamping pin for D146, ∅ 20 mm
  - 1 D283 Vibrometer
  - 12 Rods for measuring units (8x120 mm, 4x60 mm) [8x4.72", 4x2.36"]
  - 2 Offset brackets
  - 1 Magnet base
  - 1 Magnet base with turnable head
  - 2 Cables with Push/Pull connectors (2 m) [78.74"]
  - 2 Extension cables with Push/Pull connectors (5 m) [196.85"]
  - 1 Manual
  - 1 Machine tool guide
  - 1 Measuring tape
  - 1 Protective case for Display unit
  - 1 EasyLink™ Windows® program and PC cable
- Delivered in robust, aluminium framed carrying case with contoured foam insert.

## WARRANTIES AND SERVICE CONCEPT

The Easy-Laser® systems have evolved over more than 25 years, through field experience in solving measurement and alignment problems. The systems come with a 2 year limited warranty. The manufacturing and quality systems are ISO9001 approved. If an incident should occur, our service department normally handles repairs and calibrations within five working days. This combination makes Easy-Laser® a reliable partner for your business.



Easy-Laser® is manufactured by Damalini AB, Åbäcksgatan 6B, 431 67 Mölndal, Sweden, Phone +46 31 708 63 00, Fax +46 31 708 63 50, email: info@damalini.se, www.damalini.com © 2009 Damalini AB. We reserve the right to make modifications without prior notification. Easy-Laser® is a registered trademark of Damalini AB. Windows® and Excel® are registered trademarks of the Microsoft Corporation. This product complies with: SS-EN60825-1-1994, 21 CFR 1040.10 and 1040.11

